



QA Bearing Technologies manufactures customized bearings in a variety of types, sizes and stack configurations. These include specialized bearings for operation in grease, oil, and drilling mud.

QA Bearing Technologies also designs and fabricates related products that require similar attention to detail, such as shafts, housings, and sealing systems.

Our patented **DynaBearing** design is a maximum capacity cylindrical roller thrust bearing that can be manufactured specifically for your application. The two-piece, numerically machined steel cage design allows for changing the size, shape, and quantity of the rolling elements without significant tooling and provides an economical alternative for prototypes, low, and medium volume manufacturing runs.



Thrust bearings have been made in shaft sizes from $\frac{3}{4}$ " to 18" diameters.



In addition to the traditional 52100 bearing steel, materials such as 8620, 9310, and others may be supplied for greater impact resistance, wear resistance, or tensile strength. Features such as lubrication holes, grooves, chamfers, or various corner radii are easily added to suit the specific needs of your application.

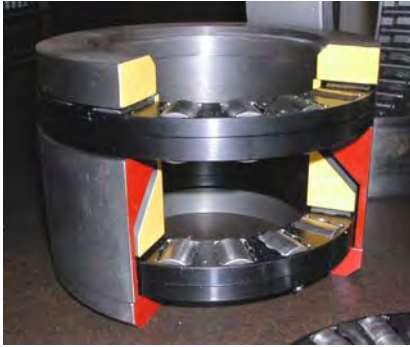

A combination of cylindrical thrust bearings may be stacked to increase their capacity even more than the single **DynaBearing**.



A number of oilfield downhole tools have their bearing section lubricated with drilling mud. **QA Bearing Technologies** manufactures the traditional four-point angular contact ball bearing stacks with identification grooves on both the inner and outer races. This helps to facilitate the matching of these separable races and insure their matching and consistent orientation during future motor rebuilds.

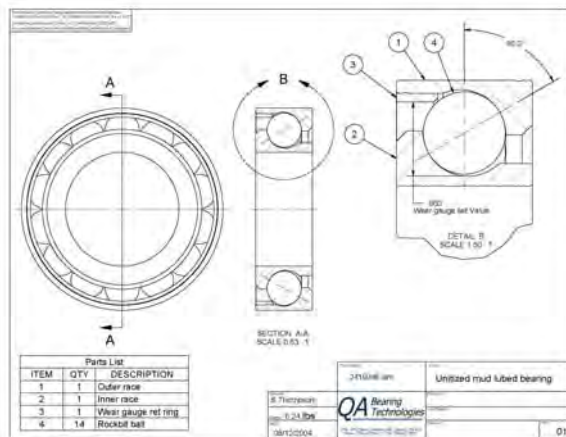
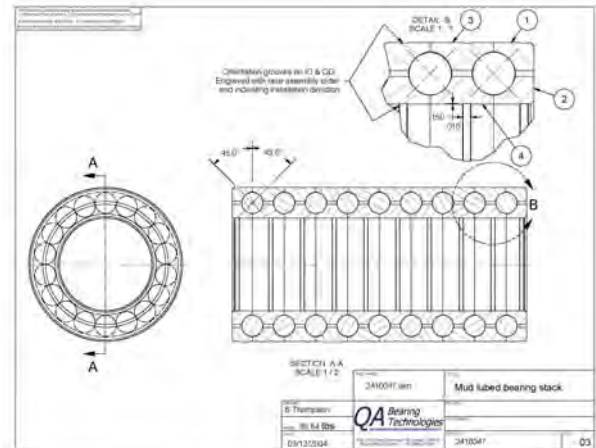

An alternative is our patented unitized angular contact ball bearing design with its wear gauge retaining ring. The unitized design eliminates the handling of loose balls and the need for matching and correctly orientating the independent races during stack and tool assembly.



The wear gauge determines when the bearings should be changed out by permitting the unit to disassemble when a predetermined amount of ball wear has occurred within the bearing.

These unitized mud lubricated bearings can be assembled into stacks with a variety of configurations to produce the required ratio of on and off bottom load capacities. The 60° contact angle provides a higher thrust load rating than the traditional 45° four-point angular contact bearing stacks for a given row of balls.

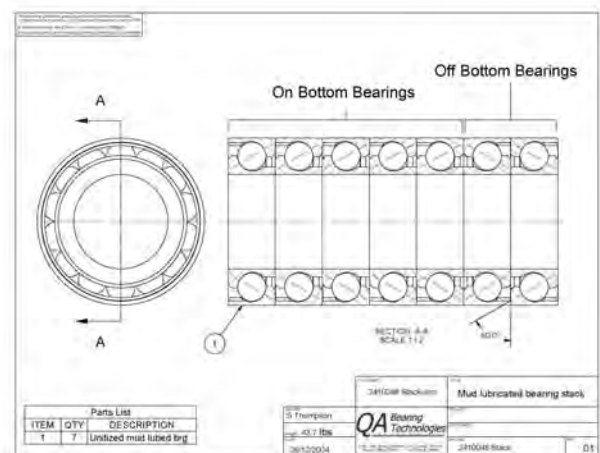

Full complement roller thrust bearings, in both sealed and unsealed configurations, are designed and manufactured in very narrow sectional widths for oilfield liner hangers, production tubing rotators, and other similar applications.



Customized radial bearing products include traditional raced bearings as well as standard and thin section cage and roller assemblies.

Thin section linear cage and roller stock may be wrapped into large diameter split needle bearing cage and roller assemblies.



Radial bushings of various materials and alignment capabilities are designed to meet your specific application requirements.



Surface treatments such as Liquid Nitride hardening or coatings like Phosphate, Teflon, or Molybdenum are options often provided. High wear and corrosion resistant materials are used for the most severe applications.



Shafts, housings, and sealing systems are also available when customers want our same attention to detail, Quality Assurance tracing, or innovative solutions for other aspects of their designs.



Traditional products such as spherical thrust bearings, tapered roller bearings, or cam followers can be modified and/or matched into assemblies for your specific needs.

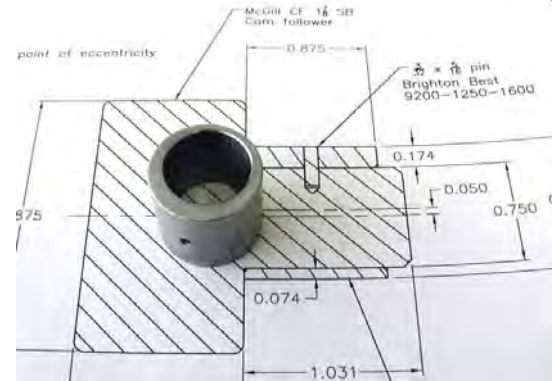

To ensure the highest quality of our product, each separable component is engraved with an identifying manufacturing code. This practice helps **QA Bearing Technologies** to track the material and heat-treat certificates for everything it supplies. Components are oiled and wrapped in a volatile corrosive inhibiting paper before they are sealed in plastic and boxed.



QA Bearing Technologies Ltd.
 9769-45th Avenue, Edmonton, Alberta, T6E 5V8, Canada
 Phone: (780) 437-9510, Fax: (780) 437-9501

QA Bearing Technologies (USA) Inc.
 11255 Windfern Road, Suite B, Houston, TX, 77064, USA
 Phone: (281) 897-9500, Fax: (281) 897-9504